

MIL-STD-1553A/B BC/RT/MT PCI DUAL TESTER/SIMULATOR CARD

DESCRIPTION

DDC's BU-65570I/72I is a versatile, PCI Card designed for the test and simulation of MIL-STD-1553 systems. It provides full, intelligent interfacing for one or two serial dual redundant MIL-STD-1553 data buses and a PCI chassis. The BU-65570I/72I can simultaneously simulate a Bus Controller (BC), up to 31 Remote Terminals (RTs), and provides a selectable, triggerable Bus Monitor (MT) for each of the four buses. The BU-65570I is a fixed voltage output 1553 card, and the BU-65572I is a variable voltage output 1553 card.

IRIG-B (Inter-Range Instrumentation Group) is a Parallel time code defined in IRIG Standard 200-95. Support is provided for IRIG receiving 1Khz Pulse Code Modulated input in both the BU-65570I and BU-65572I as a standard feature.

The BU-65572I is designed with a variable voltage output transceiver for each of the two buses. The output of these transceivers is controlled by software with a minimum of 0.2 V and a maximum of 27.0 V over a total of 2048 steps.

One of the features designed into the BU-65570I/72I is PCI Master Mode. The master mode provides the capability to transfer blocks of data to the host via Direct Memory Access in Monitor mode. DMA transfers will reduce the host processor overhead

when monitor data is being transferred from the card to host memory.

The BU-65570I/72I provides PCI true Plug and Play compatibility that greatly simplifies the installation of the card into a PCI compliant system.

The BU-65570I/72I cards provide software controllable bus connection and configuration (transformer or direct) as well as software configuration for bus termination. The bus termination is programmable to one of three values, None, Full load (37.5 ohms) and Half load (75.0 ohms)

Among all of these features, the BU-65570I/72I will still be providing all of the Bus Controller, Remote Terminal, and Monitor functions that its DDC predecessors provided. Features such as error injection, monitor filtering, and playback are incorporated in this new card.

'C', Visual Basic and LabView programming libraries are supplied with the card. These libraries provide complete control of the boards capabilities. Software control of bus loading, bus coupling and IRIG configuration is provided by the library functions developed for this card. The software libraries also provide access to the playback capabilities of the board. Each of the two buses are able to simultaneously replay and monitor previously recorded bus activity in real time.

FEATURES

- PCI Format, One or Two 1553 Buses
- Variable Amplitude Transceivers
- 64K Words of Shared RAM per Bus
- Simultaneous Emulation of BC, 31 RTs, and MT for Each Bus
- IRIG-B Interface
- DMA Data Transfers via PCI Master Operation
- Software Configuration of Bus Coupling and Termination
- PCI Plug and Play Compatible
- 32-Bit Time Tag with 1 μ sec resolution
- Replay of previously recorded Bus Traffic via Menu and Run Time Library

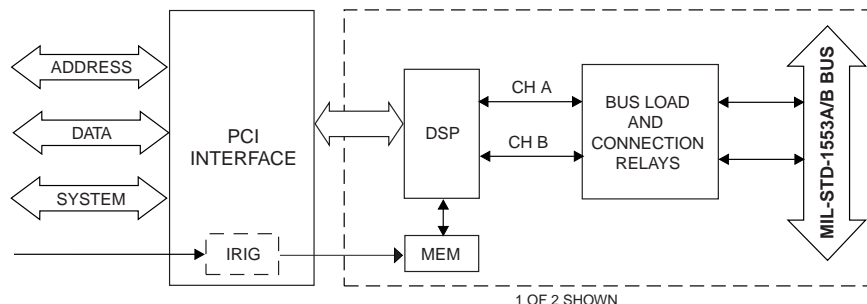

FIGURE 1. BUS-65570I OR BUS-65572I OPERATING ENVIRONMENT

TABLE 1. BU-65570I/65572I REQUIREMENTS AND CAPABILITIES

HARDWARE REQUIREMENTS
<ul style="list-style-type: none"> ■ PC compatible with one free PC slot with 486 Processor minimum required, 233 MHz Processor or better recommended ■ DDC's BU-65570I/72I, MIL-STD-1553 Tester Simukator Card
SOFTWARE REQUIREMENTS
<ul style="list-style-type: none"> ■ Windoes 95/98 or Windows NT ■ DDC's BU-65579I/72I software diskettes/CD-ROM
AVAILABLE OPERATIONS for each channel
<ul style="list-style-type: none"> ■ Tests and Simulates MIL-STD-1553 BC and all 31 RT's ■ Provides independent Monitor mode operation ■ Error injection and detection

TABLE 2. BU-65570I/72I SPECIFICATIONS

PARAMETER	MIN	TYP	MAX	UNITS
ABSOLUTE MAXIMUM RATINGS				
+5 V Supply Voltage	-0.3		7.0	V
RECEIVER				
Threshold Voltage, Transformer Coupled, Measured on Stub		0.56		VP-P
TRANSMITTER				
Differential Output Voltage				
■ Transformer Coupled, Measured on Stub	18	20	27	VP-P
POWER SUPPLY REQUIREMENTS per 1553 Bus				
Voltages/Tolerances				
■ + 5 V	4.5		5.5	V
Current Drain @ + 5.0 V				
Idle	220		240	mA
50% Transmitter Duty Cycle	720		800	mA
100% Transmitter Duty Cycle*	870		1000	mA
1553 MESSAGE TIMING				
RT Response Time (See Note 1)	4		7	µsec
BC Intermessage Gap (See Note 2)		25		µsec
BC/RT/MT Response Timeout (See Note 3)	2	29		µsec
Transmitter Watchdog Timeout		668		µsec
MT Minimum gap for capture	4			µsec
THERMAL				
■ BU-65570I/72I				
Operating Temperature	0		50	°C
Storage Temperature				°C
Shock				
Operating Humidity				
Non-operating Humidity				
PHYSICAL CHARACTERISTICS				
Size "B"	6.80(W) x 4.50(H) (172.7 x 122.9)			in (mm)
Weight	6.0 (170)			oz (g)

* (100% Duty Cycle at MAX Transmit Amplitude [28 V p-p])

NOTES:

1. This time assumes that that this card is not emulating BC.
2. This hardware time is enforced by the firmware. If an attempt to reduce this time is made , the time will be stretched to 25 µsec.
3. This time is programmable from 2 µsec to 29 µsec in 1 µsec increments.

GENERAL

The BU-65570I/72I is the next generation DDC PCI Tester/Simulator which can simultaneously simulate a MIL-STD-1553 BC, multiple (up to 31) RTs, and an intelligent MT simultaneously on both 1553 buses.

The BU-65570I/72I supports PCI "Plug and Play" installation and greatly simplifies the installation of this card into a PCI compatible computer.

Full error detection features are provided in all modes of operation. In addition, user specified errors - including bit count, Manchester II errors - may be injected in BC and any of the emulated RT modes.

Operational characteristics of the BU-65570I/72I such as output voltage level, bus termination, and coupling configuration are all software controllable using functions provided in the software library.

TABLE 3. J1 - DISCRETE I/O

PIN	DESCRIPTION
1	N/C
2	Chassis Ground
3	Chassis Ground
4	Chassis Ground
5	IRIG Mod
6	Discrete Out 1
7	Discrete Out 2
8	Discrete Out 3
9	Discrete Out 4
10	Discrete Out 5
11	Discrete Out 6
12	Discrete Out 7
13	Discrete Out 8
14	Chassis Ground
15	+5 Volts
16	+5 Volts
17	IRIG In
18	Channel 1 Monitor Trigger In
19	Channel 1 Monitor Trigger Out
20	Channel 1 BC Trigger In
21	Channel 1 BC Trigger Out
22	Channel 2 Monitor Trigger In
23	Channel 2 Monitor Trigger Out
24	Channel 2 BC Trigger In
25	Channel 2 BC Trigger Out

TABLE 4. J2 - 1553 BUS 'D' CONNECTOR

PIN	DESCRIPTION
1	CH1_TXA_L
2	CH1_TXA
3	CH1_TXB
4	CH1_TXB_L
5	GND (connected to shell)
6	CH2_TXA_L
7	CH2_TXA
8	CH2_TXB
9	CH2_TXB_L

BUS CONTROLLER MODE

The BU-65570I/72I Bus Controller supports all MIL-STD-1553B message formats. Up to 1000 unique receive, transmit, mode code, and RT to RT messages may be defined at one time for each of the installed channels.

Programmable attributes within a message include time to next message, bus (channel A or channel B), intermessage routines, and injected error. The time to next message defines the time from the start of the present message to the start of the next message. The time to next message is programmable up to 65,535 msec in 1- μ sec increments.

MINOR AND MAJOR FRAMES

The execution of messages is controlled by a message list referred to as a frame. The frame specifies the contents and timing of complete communication runs by the BC. Each entry in the frame is either a reference to a message or a special frame symbol. The entire frame is referred to as a major frame and is divided into minor frames each of equal time duration.

The minor frame time is based on a programmable 32-bit counter with 1 msec resolution. The BU-65570I/72I supports major frames of up to 1000 messages per installed channel, with a period of up to 72 minutes.

BC ERROR INJECTION

Error conditions may be injected on a message by message Basis. The BU-65570I/72I supports three categories of injected BC Errors: length errors, encoding errors, and gap errors. Length Errors include both word count errors and bit count errors.

Word Counts of -32 to +1 words may be programmed. Bit counts of +3, +2, +1, -3, -2, or -1 bit may be programmed on any word within the message.

Encoding errors are implemented though the use of two simple yet powerful mechanisms for modifying the output of the BU-65570I/72I's Manchester encoder. The two modifying functions are glitch and inverse. A glitch error will force the output of the encoder to an idle bus condition for the specified period of time.

An inverse error will invert the output of the encoder for the specified period of time. The word number, starting time, and width

specify the placement of the error. The error may be placed in any word within the message and its starting time may be programmed in 500 nsec with a width of up to 3 μ sec. This error injection is capable of generating a host of errors including invalid sync patterns, parity errors, and Manchester bi-phase errors.

A gap of 3, 4, or 5 μ sec (measured mid-parity crossing to mid-sync crossing) may be inserted between any two words in a message. This allows for a "dead time" gap between words of 1,2, or 3 μ sec.

INSERTING ASYNCHRONOUS MESSAGES

The BU-65570I/72I allows an asynchronous message to be inserted while the card is running. The inserted message will be executed upon completion of the current message. The user will define all asynchronous messages after the End-Of-Major frame symbol and insert the message into the running frame by calling the insert message routine. The hardware does all of the work.

BC INTERMESSAGE ROUTINES

Upon completion of a BC message, the BU-65570I/72I's on-board processor will execute up to 2 intermessage routines. Intermesage routines are used to implement automatic retries on failed messages as well as other "end of message" functions. TABLE 5 provides a summary of the BU-65570I/72I's intermessage routines.

RESPONSE TIMEOUT

The BU-65570I/72I BC RT's and MT support programmable response timeout values ranging from 2 to 29 μ secs in 1- μ sec increments.

RT MODE

The BU-65570I/72I can simultaneously simulate the operation of 31 unique remote terminals (RTs) plus a broadcast address for each of the installed channels. The BU-65570I/72I maintains 31 independent "last status" and "last command" words allowing for full support of transmit last command and transmit status mode commands. The BU-65570I/72I supports full RT command illegalization for each transmit or receive message based on RT address and sub-address. In addition, individual mode commands may be illegalized.

RT ERROR INJECTION

Error conditions may be injected on an individual RT/SA basis. The BU-65570I/72I supports five categories of injected RT errors: length errors, encoding errors, gap errors, status address errors, and response errors. Length errors include both word count errors and bit count errors. Word counts of -32 to +1 words may be programmed. Bit counts of +3, +2, +1, -3, -2, or -1 bit may be programmed on any word within the message.

Encoding errors are implemented though the use of two simple yet powerful mechanisms for modifying the output of the BU-65570I/72I's Manchester encoder. The two modifying functions are glitch and inverse. A glitch will force the output of the encoder to an idle bus condition for the specified period of time. An inverse will invert the output of the encoder for the specified

period of time. The word number, starting time, and width specify the placement of this error. The error may be placed in any word within the message. The starting time is programmed in 500 nsec increments from the beginning of the specified word.

The width of the error is specified in 50 nsec increments up to 3 μ sec. This error injection scheme lends itself to generating a host of errors including invalid sync patterns, parity errors, and Manchester bi-phase errors.

A gap of 3, 4, or 5 μ sec (measured mid parity crossing to mid-sync crossing) may be inserted between any two words in message. This allows for a "dead time" gap between words of 1, 2, or 3 μ sec. A status address error may be injected in which the RT responds with a status word containing a RT address, which does not match the terminal's RT address. The RT may be programmed to respond with any value from zero to 31 in its status response.

The BU-65570I/72I supports three types of response errors: no response, a late response, or a response on the wrong bus. No response errors may be programmed for a single bus (Bus A or Bus B) or for both buses. Injecting a no response error on one bus provides a simple mechanism for testing bus controller retry conditions. A late response may be programmed in the range of 2 to 30 μ secs in 1 μ sec increments

RT INTERMESSAGE ROUTINES

The RT section of the BU-65570I/72I also supports intermessage routines. Upon completion of a RT message the BU-65570I/72I's on-board processor executes two intermessage routines. The data table that was used by the RT for a given message specifies which intermessage routines will be executed. Refer to TABLE 5 for a summary of the BU-65570I/72I's intermessage routines.

BC/RT DATA TABLES

For each of the installed 1553 channels, the BU-65570I/72I maintains 1000 data tables within the shared RAM. Each data table may be up to 32 words in length. These data tables are common to both BC and RT. Internal lookup tables map each RT address, T/R, sub-address combination (RT mode) and message number (BC mode) to a chosen data table. Data tables may be read or written to in real time by the user and may be either single or double buffered. Double buffering can be used to avoid the memory access contention that occurs when the PC's application and the 1553 bus access data tables simultaneously. The BU-65570I/72I provides an optional block data mode in which the data table number associated with a given BC or RT message is incremented after completion of the message. The block data mode is implemented as a circular data structure. Each BC message and RT command (RT address, T/R, and sub-address) has three data table numbers associated with it: first, last, and current. The current data table number will be incremented after completion of message until the value of 'last' is reached, at which point the current table number will rollover to the value of first. The incrementing of the current data table is accomplished through the use of an intermessage routine.

TABLE 5. BC/RT INTERMESSAGE ROUTINES
NO OPERATION
RETRY CURRENT MESSAGE ON ALTERNATE BUS
RETRY CURRENT MESSAGE AND REMAIN ON ALTERNATE BUS
RETRY ON SAME BUS
INTERRUPT ON END OF MESSAGE
INTERRUPT ON FRAME SYMBOL
SET SERVICE REQUEST BIT IN STATUS
RESET SERVICE REQUEST BIT IN STATUS
INTERRUPT AFTER ACCESSING TX/RX DATA TABLE
INTERRUPT AFTER MODE COMMAND
INTERRUPT AFTER TX/RX COMMAND TEMPLATE MATCH
INTERRUPT AFTER MODE COMMAND TEMPLATE MATCH
TIME-TAG (STORE RTC IN A CIRCULAR QUEUE)
RETRY ON SAME BUS AND THEN ON ALTERNATE BUS
SET OUTPUT TRIGGER
WAIT FOR INPUT TRIGGER
NO RESPONSE ON BOTH BUSES
SET BUSY BIT IN STATUS
RESET BUSY BIT IN STATUS
SKIP NEXT MESSAGE
SKIP NEXT MESSAGE ONCE
BLOCK_DATA_BC
BLOCK_DATA_RT
SET_DISCRETE_0
RESET_DISCRETE_0
SET_DISCRETE_1
RESET_DISCRETE_1
SET_DISCRETE_2
RESET_DISCRETE_2
SET_DISCRETE_3
RESET_DISCRETE_3

MONITOR MODE

The BU-65570I/72I contains an independent message monitor for each bus with the ability to filter messages in real time. Monitor selection or filtering is performed through the use of a lookup table based on the RT address, T/R, and sub-address of command words. Monitored messages are stored in the shared RAM on the BU-65570I/72I. Each entry in the monitor buffer contains a header followed by a variable number of data words. Contained with the message header are the receive/transmit command(s), receive/transmit status, message format, Bus (A or B), a capture flag, word count (actual number of words in the message), a detected error field, and a 32-bit time tag (1 msec resolution).

The transfer of the messages from the card's circular buffer to the host memory/disk is determined by the capture flag, which is set upon detection of a predefined event. Capture events include

immediate, command template match, exception, or trigger. The command template event is based on a 16-bit command word with a 16-bit mask. Exception events may be programmed for any exception: invalid command, invalid data, invalid status, gap preceding data, response time error, wrong RT address error, status set condition or an illegal command. The trigger event uses one of the four monitor input pins on the 9-pin D-type connector as a trigger input.

DMA transfers are possible using the PCI Master Mode. The Monitor mode can autonomously transfer monitored data to the host without host CPU intervention. This greatly improves the efficiency of both the host and the BU-65570/72I.

INTERRUPTS

For each of the installed channels, both the BC/RT and the Monitor may request interrupts on a common output to the PCI back plane. The hardware interrupt level used by the BU-65570I/72I is selected by the Plug-and-Play capability of the PCI back plane and BIOS. An important aspect of PCI interrupts is that they are sharable. This means that the BU-65570I/72I can share an interrupt for all buses on the card.

BC INTERRUPT GENERATION

BC interrupts may be enabled by a global interrupt mask for successful messages, communication errors, status set conditions, or on selected frame symbols (skip, break point, major frame, and minor frame symbols). The criteria for a status set condition are programmed globally through the use of a status mask. The status mask allows any of the 16 bits within the RT status word to be ignored. The status mask affects the generation of interrupts as well as the detected error field that is stored in the message structure.

BC interrupts are issued by the intermessage routines associated with messages allowing for selective interrupt generation on a message by message basis. A two-word vector is pushed onto a circular queue for each interrupt request and is transparent to the user. The queue can hold up to 64 interrupt vectors; thus, the host computer is not required to immediately acknowledge the interrupt request.

RT INTERRUPT GENERATION

RT interrupts may be enabled by a global interrupt mask for transmit/receive messages with no message error, mode commands with no message error, transmit/receive messages with the message error bit set, or mode commands with the message error bit set.

RT interrupts are issued by intermessage routines associated with data tables allowing for selective interrupt generation on a message by message basis. A two-word vector pushed onto a circular queue for each interrupt and is transparent to the user. The queue can hold up to 64 interrupt vectors; thus, the host computer is not required to immediately acknowledge the interrupt request.

MONITOR INTERRUPTS

Monitor interrupts may be generated after each message is received or after one third of the monitor's circular buffer has been filled (approximately 2K words). This allows for either real-time analysis or mass collection/storage of monitored data.

OTHER FEATURES

VARIABLE AMPLITUDE TRANSCEIVER

The BU-65572I provides variable amplitude transceivers for each 1553 channel installed on the card. The output of the variable transceiver is software controllable in the range of 0.2 volts to 27.0 volts. This range is covered in 2048 steps. The user application is able to modify this amplitude in real by calling the appropriate library function.

The transceiver outputs can be individually controlled for each of the installed channels, while the two transceivers for a given channel will be varied simultaneously. Functions for controlling the transceiver outputs are added to the 'C' library that is provided with the card.

IRIG-B SUPPORT

Inter-Range Instrument Group (IRIG) Standard 200-95 is provided in the BU-65570I/72I boards. The implementation of this standard into the 1553 tester/simulator board enables all messages to be tagged with time-of-day information, allowing accurate correlation between messaging on the 1553 bus and other hardware and software events that are occurring in the system. This is especially useful when trying to identify the cause of a system problem that may be directly related to message data sent over the 1553 bus. The IRIG-B timestamp for each of the installed channels may be individually selected. This allows one channel to use the internal 32 bit Time-Tag clock, while another channel will stamp the messages with the IRIG-B time. The IRIG-B timestamp, if enabled, will be combined with the internal timestamp to provide uSec accuracy.

MONITOR DMA TO HOST BUFFER

The BU-65570I/72I is fully compliant to the PCI standards for both Target and Master applications. As a PCI master, the BU-65570I/72I is capable of performing DMA block data transfers from the monitor buffers on the card to a user buffer in the host memory. This will allow the transfer of data without interrupting the host processor, enabling it to perform other more important tasks.

PCI PLUG AND PLAY

PCI Plug and Play is provided on the BU-65570I/72I. Both BIOS and the operating system can now determine the memory and interrupt resources to be used by this card. The memory is selected from the system memory above 1 meg. The system will generally select unused locations starting at the 4 gig address and work its way down. The interrupts for PCI are sharable. This means that if there are no free interrupt resources, the operating system can now assign an interrupt that is used by another PCI card. The driver will handle all of the elements of sharing.

SOFTWARE CONTROL OF BUS CONFIGURATION

The BU-65570I/65572I has the capability of being connected to the bus as either Transformer Coupled or Direct Coupled. Transformer coupling enables the card to be connected to the 1553 bus with a long stub of up to 20 feet. Direct coupling requires that the card be connected to the 1553 bus by a stub of no more than 1 foot. The coupling configuration is dynamically configurable via functions provided in the 'C' library. Relays on the board are used to select the correct signal path direct or transformer coupled for each of the installed channels. This card also has the capability of modifying the bus termination to one of three different loads. If the bus termination is set to None, then the effective impedance is infinite ohms. If the bus is set to Full, then the bus termination will be 37.5 ohms. A setting of Half will cause a bus termination of 75.0 ohms. This control makes it quite simple to connect the 65570I/72I directly to another 1553 device without the need of an external load. As with the bus coupling mode, the bus termination mode is dynamically configurable via software functions provided in the 'C' library which control relays for each installed channel.

DISCRETE OUTPUTS

This new Tester/Simulator design will include four discrete outputs per channel. These four outputs are set to logic '1' and cleared to logic '0' by use of eight new intermessage routines. The format of the routine names is SET_DISCRETE_X and RESET_DISCRETE_X. These discrete outputs may be used for signaling external equipment when a specific event or message has occurred. The intermessage routine can be attached to any message, data table, or frame symbol providing a wide variety of debug possibilities.

SOFTWARE SUPPORT

The BU-65570I/65572I will be provided with a 32-bit 'C' library that supports all of the functionality of the previous versions of the DDC Tester/Simulator cards. This will make re-hosting of existing software as simple as a re-compile. The new library will also contain new functions that will enable full use of all of the new hardware functionality such as IRIG-B, Monitor DMA, Dynamic Bus Configuration, and Dynamic Bus Loading.

A full function Menu is also supplied with the BU-65570I/72I. Running on Windows 95/98/NT, the new menu will provide access to all hardware functions except DMA. The menu is an extension of the existing Tester/Simulator menu and is completely compatible with setup and stack files that are used with the older version.

A new feature added to the menu is a "Ccode Generate" button that will convert an entire setup to editable/compilable 'C' source code. This will allow the major portion of Setup to be done in the menu, and any data reduction routines can be added to the generated source, the final product can then be compiled under any 'C' compiler and run.

Additional support will be provided for LabView application development.

Drivers for the BU-65570I/72I are provided for Windows 95/98/NT running on an Intel platform in a PCI chassis.

ORDERING INFORMATION

BU-6557X I X-300 Simulator and Tester PC Card

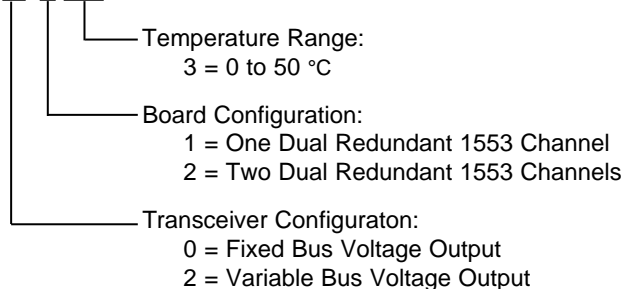

Software Included :

- Windows 95 Menu
- Windows NT Menu

32-bit Windows DLL/Driver supports Borland and Microsoft 32-bit C/C++ Compilers, and National Instruments Laboratories development.

NOTES

The information in this data sheet is believed to be accurate; however, no responsibility is assumed by Data Device Corporation for its use, and no license or rights are granted by implication or otherwise in connection therewith. Specifications are subject to change without notice.



105 Wilbur Place, Bohemia, New York 11716-2482

For Technical Support - 1-800-DDC-5757 ext. 7257 or 7381

Headquarters - Tel: (631) 567-5600 ext. 7257 or 7381, Fax: (631) 567-7358

West Coast - Tel: (714) 895-9777, Fax: (714) 895-4988

Southeast - Tel: (703) 450-7900, Fax: (703) 450-6610

United Kingdom - Tel: +44-(0)1635-811140, Fax: +44-(0)1635-32264

Ireland - Tel: +353-21-341065, Fax: +353-21-341568

France - Tel: +33-(0)1-41-16-3424, Fax: +33-(0)1-41-16-3425

Germany - Tel: +49-(0)8141-349-087, Fax: +49-(0)8141-349-089

Sweden - Tel: +46-(0)8-54490044, Fax +46-(0)8-7550570

Japan - Tel: +81-(0)3-3814-7688, Fax: +81-(0)3-3814-7689

World Wide Web - <http://www.ddc-web.com>

